



THE QUIET ONE®

The Quietest Commercial Blender Available

The ultimate blender with unparalleled sound reduction, exceptional beverage blends, and improved speed of service.

Smart Product Design

- Up to 4 times quieter than the competition due to the advance vibration dampening technology; resulting in quality drinks in a more enjoyable atmosphere
- Magnetically secured floating sound enclosure is dramatically easier to clean and disassemble. No screws to damage the enclosure
- Variable speed control and automatic shut-off provide flexibility in creating endless recipes. 6 program buttons with 34 optimized programs for easier, consistent blending
- Advance® container creates faster, smoother pouring and has a longer blade life resulting in time and cost savings along with improved customer experience
- Air management and powerful ≈ 3 peak output HP motor reduces noise, improves reliability and reduces down time

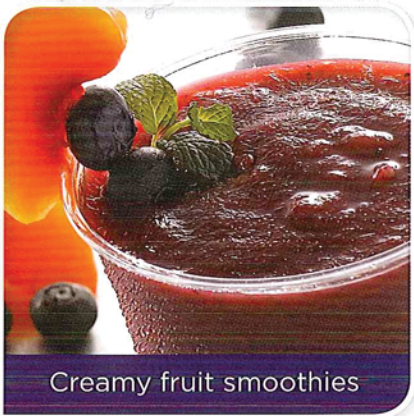

Creamy fruit smoothies

Product Specifications

The Quiet One®

On-Counter: Item No. 50031 / In-Counter: Item No. 51024

Motor: ≈3 peak output horsepower motor

Electrical: 220 - 240 V, 50/60 Hz, 1300 - 1500 W

Pack: Includes The Quiet One® with 1,4 L high-impact, clear/stackable Advance® container complete with Advance blade assembly and lid, and removable compact enclosure.

Net Weight: 9,1 kg, (12,7 kg with box)

Dimensions:

On-Counter: 45,7 x 21,6 x 27,2 cm (H x W x D)
Height with lid open: 62,2 cm

In-Counter: 41,9 x 21,6 x 27,2 cm (H x W x D)
Height with lid open: 58,4 cm
Depth below counter: 3,0 cm

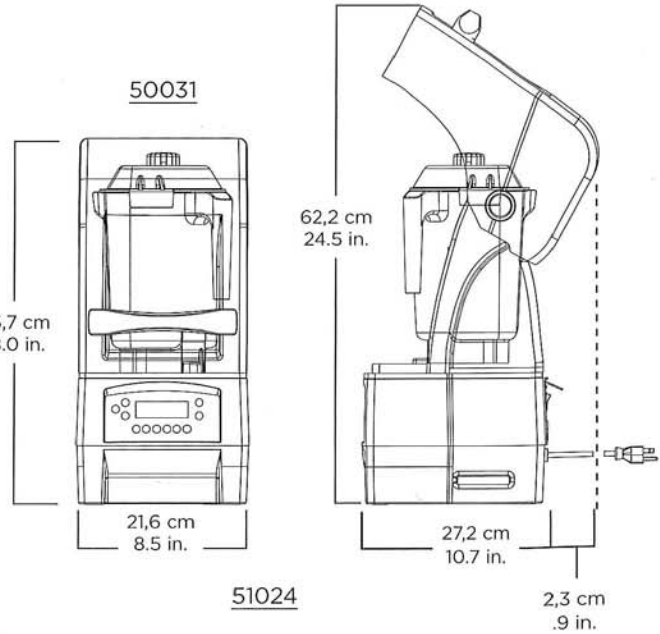

Warranty: Please contact your authorized Vitamix distributor for warranty information.

Also Available

The Quiet One On-Counter with Advance container

Item No. 36209: 120 V (EMC), 50/60 Hz, 15,0 A

Item No. 52005: 100 V, 50/60 Hz, 1300 W

The Quiet One In-Counter with Advance container

Item No. 36300: 120 V (EMC), 50/60 Hz, 15,0 A

Item No. 53005: 100 V, 50/60 Hz, 1300 W

Additional containers, complete with blade assembly and lid.

Item No. 15978: Advance container 1,4 L

For more information, please contact an authorized Vitamix distributor, or Vitamix international customer service.



Where applicable:



Contact Information



Aishwarya Consolidates Pvt. Ltd.,

#19, Frist Floor, 10th 'B' Main, 27th Cross,
Third Block Jayanagar, BANGALORE – 560 011, INDIA

Tel: +91-80-2664 1200/1/2 Fax: +91-80-2664 1204

E-mail : aishtek@vsnl.com www.aishwaryaconsolidates.com